



AS3360 - Dual Voltage Controlled Amplifier (VCA)

FEATURES

- Two Independent VCAs in a Single 14 Pin package
- Simple to Use - Few External Components Required
- Exceptionally Low Control Feedthrough Without Trimming: 10mV Maximum Out of 10 V.P.P. Output
- Low Noise: -110 dB Typical
- No Trimming Required
- Summing Node Signal Inputs
- Current Outputs Capable of Swinging to Within 1.5V of Each Supply
- Linear and Exponential Control
- Control Voltages Referenced to Ground
- Wide Supply Range: $\pm 3V$ to $\pm 12V$ or $+15V, -3V$ to $-9V$

APPLICATIONS

for electronic music

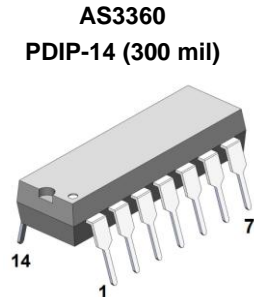

General Description

The AS3360 is a dual general purpose voltage controlled transconductor intended for such applications as voltage controlled amplifiers, filters, and waveform generators. Each transconductor independently provides both linear and exponential control scaling over greater than a 100 dB range. Complete with virtual ground summing inputs, wide voltage compliance current outputs, and control inputs referenced to ground, the AS3360 requires exceptionally few external components and is extremely easy to use.

Because of its inherent ultra-low control feedthrough, no trimming is required. Added to these features are exceptionally low noise, wide bandwidth, and operation down to ± 3 volts, making the AS3360 a real cost saver in most applications requiring variable transconductance amplifiers.

Pin Information

PDIP-14 SOIC-14 Pin No	Pin Name	Description
1	GND	Ground
2	Io1	Signal Output 1
3	VE1	Exp. Control Voltage Input 1
4	VO1	Log Converter Output 1
5	Vc1	Linear Control Input 1
6	Ii1	Current Input 1
7	VEE	Negative Supply Voltage
8	VREF	Reference Voltage
9	Ii2	Current Input 2
10	Vc2	Linear Control Input 2
11	VO2	Log Converter Output 2
12	VE2	Exp. Control Voltage Input 2
13	Io2	Signal Output 2
14	VCC	Positive Supply Voltage

Block and Connection Diagram

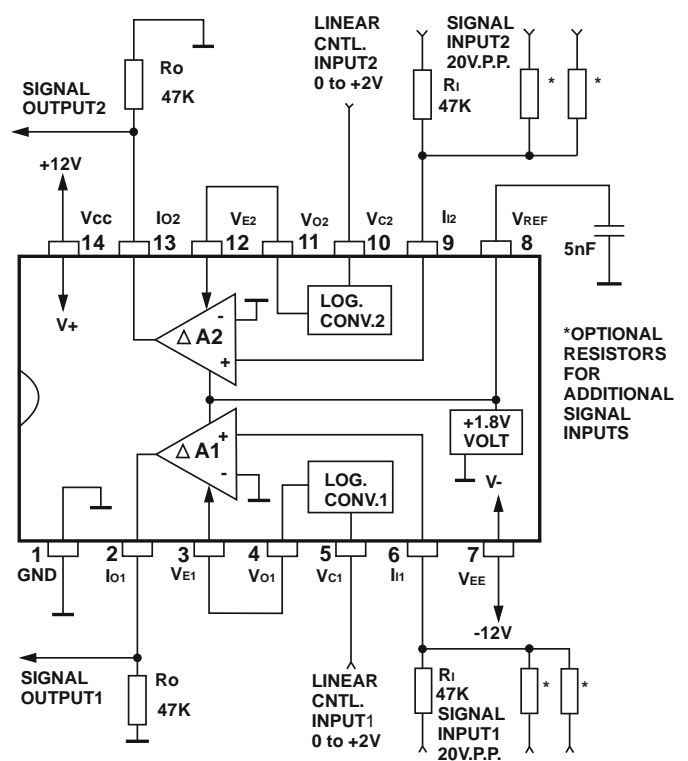

Connection for exponential control scale

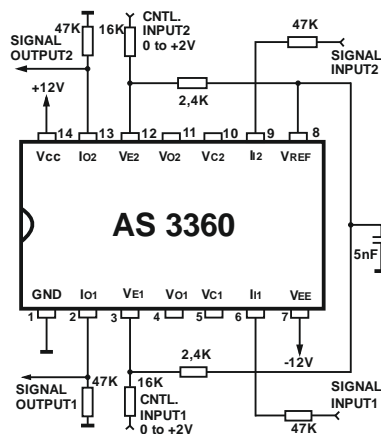



Absolute Maximum Ratings

Voltage Between V_{CC} and V_{EE} Pins	26V
Voltage Between V_{CC} and GND Pins	+3V to +16V
Voltage Between V_{EE} and GND Pins	-3V to -16V
Linear Control Voltage	-2V to +2,5V
Exponential Control Voltage	-2V to +2,5V
Storage Temperature Range	- 55°C to 150°C
Operating Temperature Range	- 25°C to +75°C

Typical Electrical Characteristics

$V_{CC}=+12V$ $V_{EE} = -12V$ $T_A= 20^\circ C$

Parameter	Min.	Typ.	Max.	Units
Control Range, Linear and Exponential	100	-	-	dB
Control Scale Factor				
Exponential ¹	+ 2,7	+ 3	+ 3,3	mV/dB
Linear	48	52	56	%/V
Tempco of Control Scales				
Exponential	+ 3000	+ 3300	+ 3600	ppm
Linear	-	±250	±750	ppm
Control Scale Error				
Exponential ²	-	0,6	2	dB
Linear	-	3	6	%
Maximum Cell Current Gain ³	0,9	1	1,1	
Maximum Signal Input and Output Current	±300	±400	±500	µA
Signal Input Offset	-10	0	+ 10	mV
Control Feedthrough Without Trim ⁴	-	±0.07	±0.3	µA
Total Harmonic Distortion ³	-	1	3	%
Output Noise Current ⁵	-	0,4	1,2	nA R.M.S.
Signal Current Bandwidth	2	5	-	MHz
Signal Current Slew Rate ³	0.5	1.5	-	mA/µS
Crosstalk Between VCAs ⁶	-80	-90	-	dB
Signal Attenuation for Linear Control Input = 0V ⁷	70	80	-	dB
Linear Control Voltage for Maximum Gain	1,6	1,7	1,8	V
Exponential Control Voltage Range, Referred to V_{REF} (Pin 8)	+ 20	-	-280	mV
Control Input Bias Current				
Exponential ³	-0,3	-0,8	-1,5	µA
Linear	-0,5	-1,6	-4	µA
Output Impedance ³	5	12	-	MOhm
Output Voltage Compliance ³	$V_{EE}+1.2$	-	$V_{CC}-0.8$	V
Reference Voltage (Pin 8)	1,6	1,7	1,8	V
Positive Supply Voltage Range ⁸	+3	-	+16	V
Negative Supply Voltage Range ⁸	-3	-	-16	V
Supply Current	3,8	4,8	6	mA

Note 1. Current gain is - 20dB to - 80dB. Control voltage is referenced to pin 8.

Note 2. Best straight line. Most of this error occurs at range extremities.

Note 3. Output Signal Current is ±100µA.

Note 4. Over entire control range. Signal input is open.

Note 5. In 16 to 16KHz bandwidth.

Note 6. At 1KHz.

Note 7. For negative supply less than 12 volts, this attenuation is greater.

Note 8. Total supply voltage across chip should not exceed 26V.

Specifications subject to change without notice.



Device type	Package
AS3360	PDIP-14 (300 Mil)
AS3360D	SOIC-14 (150 Mil)

Package Information

Units: inch (mm)

PDIP-14 (300 mil)

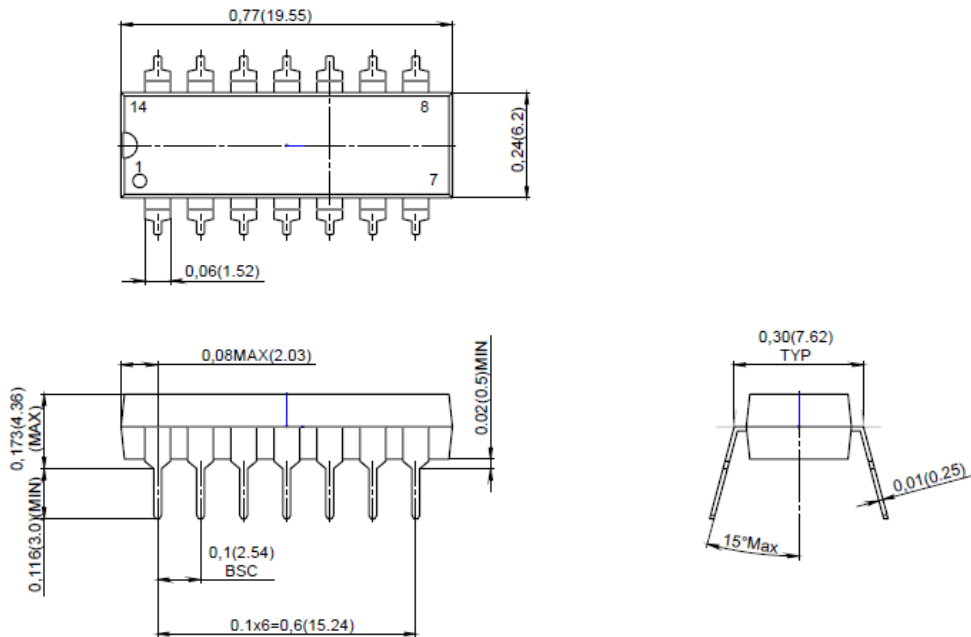

SOIC-14 (150 mil)

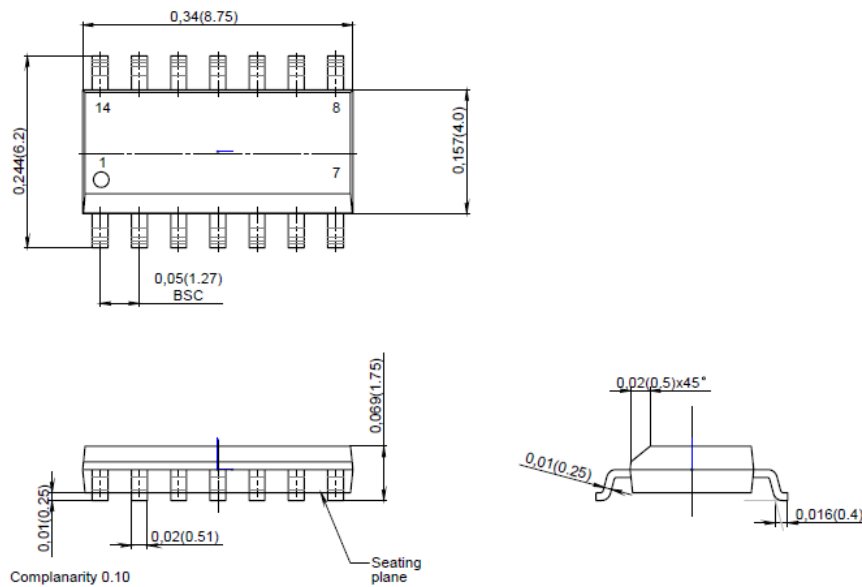

Revision history

Date	Revision	Changes
27-Sep-2017	1	Preliminary version 1
21-May-2018	2	The control voltage range at the linear control input and Reference Voltage are adjusted
30-May-2018	3	Minor changes
12-Nov-2018	4	Figure - Connection for exponential control scale